

Chase Loft Twin Bunk Bed Assembly Instructions

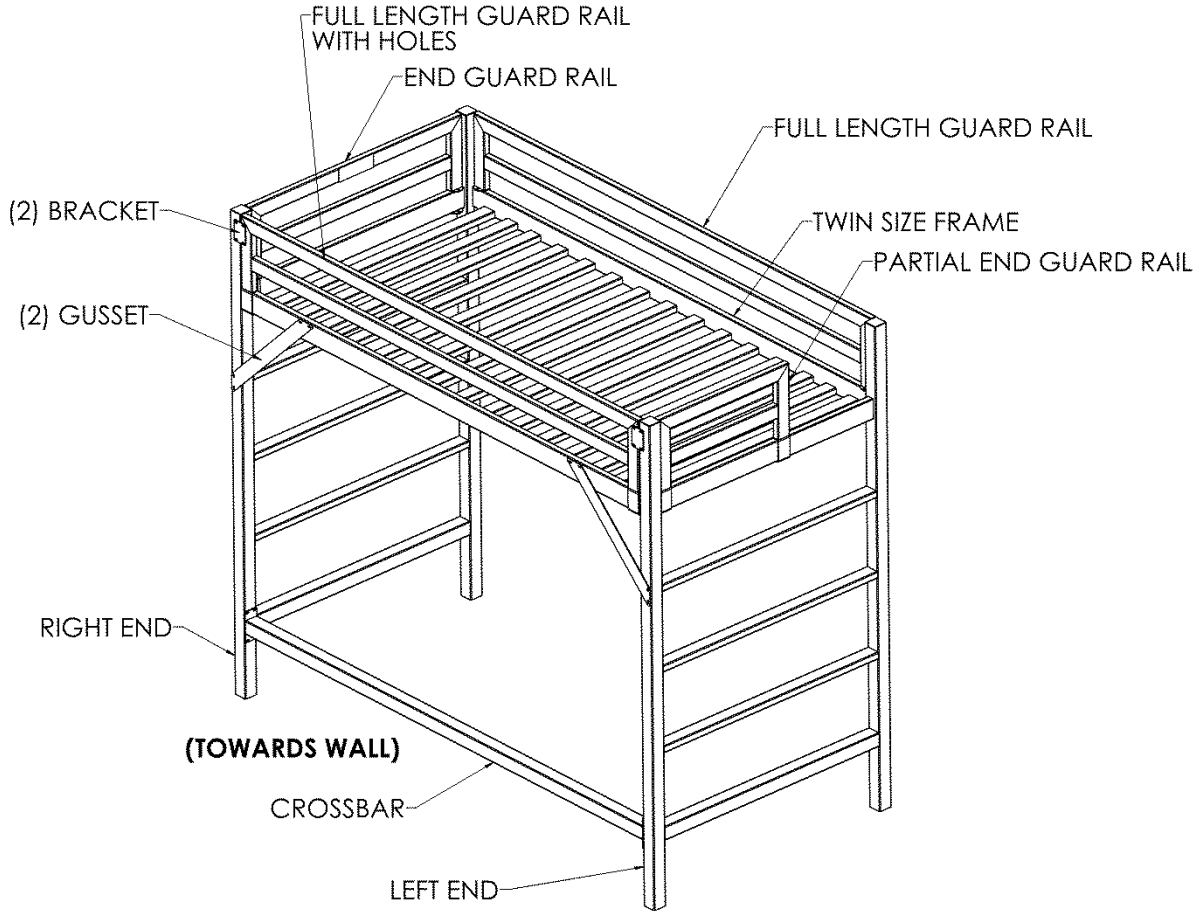

List of Parts:

- 1 – Right end (Holes toward wall)
- 1 – Left end (Holes toward wall)
- 1 – Twin Size Frames
- 1- Full length guard rail with holes for bracket attachment and 2 screw/nut assemblies attached (Holes toward wall)
- 1- Full length guard rail with 2 screw/nut assemblies attached (Front)
- 1- End guard rail with 2 screw/nut assemblies attached
- 1- Partial end guard rail with 2 screw/nut assemblies attached (Used on ladder end)
- 1 - Crossbar
- 2- Gussets
- 2 – Brackets (To secure guard rail to end)

Hardware:

- 8 - screw/nut assemblies attached to appropriate component
 - Each screw/nut assembly includes:
 - 1 Nut – 3/8” Square, 3” long
 - 2 screws 10-24 screws x 1/2”
- 24 - #10 x 3/4” Self-drilling screws

Tools required:

Phillips screwdriver

People required:

2 People are required for assembly. You need a person on each side of the bed during assembly. The 2 people will be required to lift 100 lbs to a height of 55" and hold long enough to slide the rails of the twin size frame piece over the clips on the bed ends.

Assembly Instructions:

1. Assemble the Crossbar to the Right and Left ends. The holes in the left and right end should line up with the holes in the crossbar. Connect the crossbar to the ends using (8) #10x3/4" self-drilling screws, Do Not fully tighten yet.
2. Position the bunkbed so the crossbar is toward the wall. Leave enough space away from the wall for a person to get in to lift the twin size frame into place.
3. With the Right and Left ends upright, lift the Twin size frame (holes in side rail of Twin size frame must be on same side as crossbar) so the tab of the rails fit over the clip on the Right and Left ends. If the rails on the Twin size frame are not all the way down you may need to tap it down with a rubber mallet. Now fully tighten the crossbar screws.

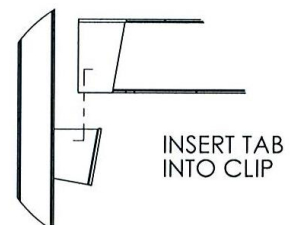
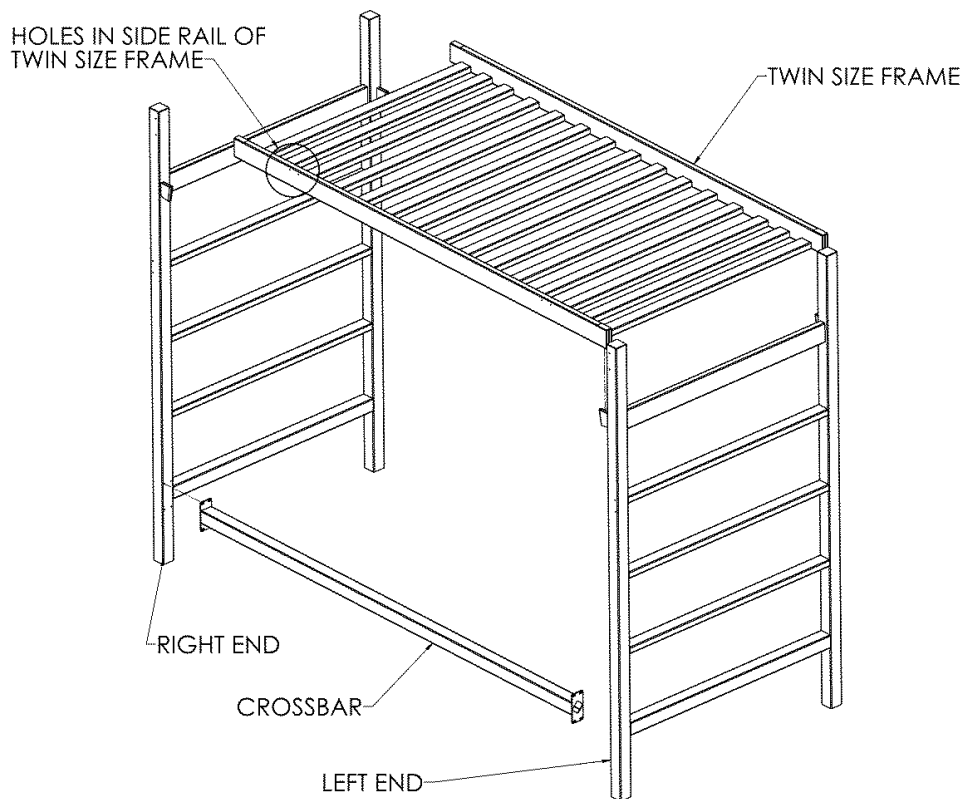

4. Remove the screws from the screw/nut assembly on the Full length guard rails. Attach the full length guard rails with holes to the sides of the Twin size frame above the crossbar. The Full Length Guard rail without holes should go on the opposite side. With a person at each end of the Full length guard rail, slide the C bracket over the 3" top rail with the holes to the inside of the bed. Place the Full length guard rail so the space at each end is equal. Insert a long square nut between the holes in both C brackets. Insert screws through C bracket holes (top & bottom) and screw them into the long square nut. Tighten the top screw first, then the bottom screw with screwdriver.

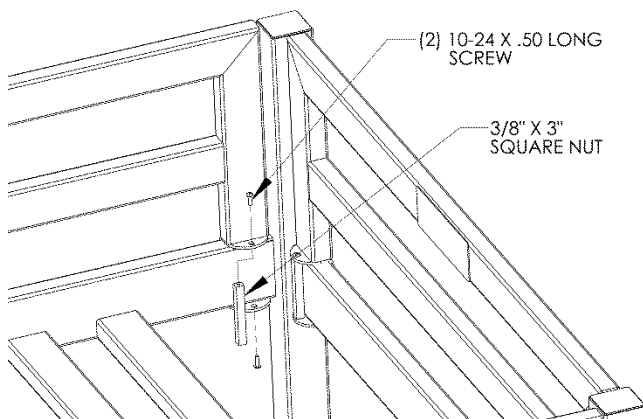
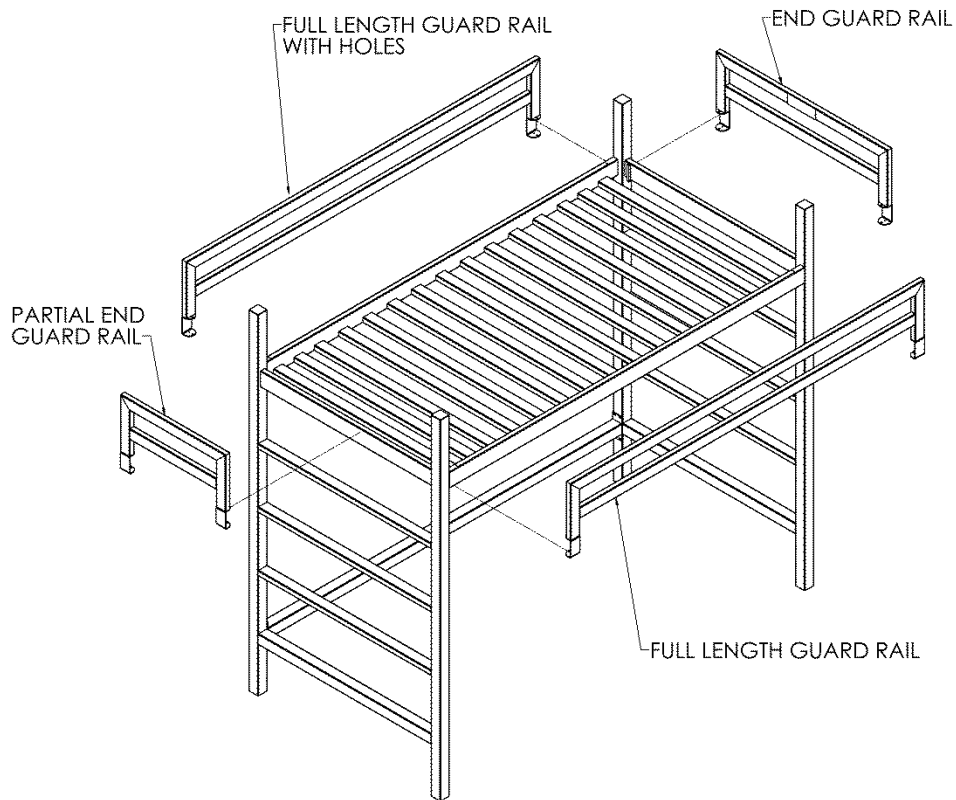

5. Decide which end you want the ladder and assemble the Partial end guard rail on that end. Position the partial guard so that it is toward the wall side, leaving the opening toward the front of the bed. Attach the partial end guard rail in the same manner as the Full length guard rails. Repeat step on the other end with the End guard rail.
6. Assemble 2 Brackets and 2 Gussets on each end using (16) #10x3/4 self-drilling screws as shown.

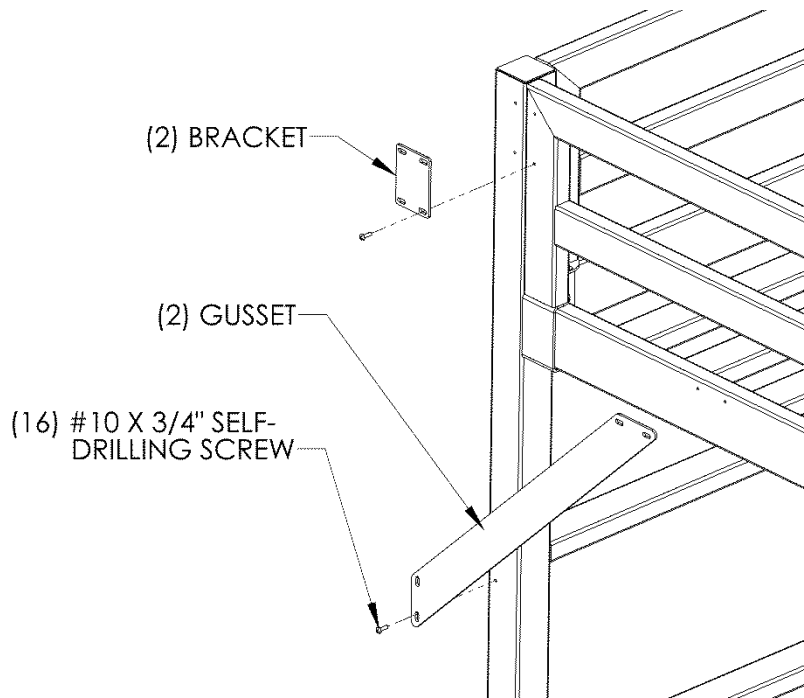

7. Slide bed into final position.
8. Put twin mattress in place both bottom and top.
Use only mattress which is 74"-75" long and 38-1/2"-39-1/2" wide on upper bunk. For upper and lower bunks, ensure the thickness of the mattress and foundation combined does not exceed 7" and surface of mattress is at least 5" below upper edge of guardrails.

Important Safety Warnings:

1. Follow the information on the warnings appearing on the upper bunk end structure. Do not remove warning label from bed.
2. Always use the recommended size mattress or mattress support, or both, to help prevent the likelihood of entrapment or falls.
3. Ensure that the mattress and foundation does not exceed 7". Surface of mattress must be at least 5" below the upper edge of the guard rails.
4. Do not allow multiple people or children under 6 years of age to use the upper bunk.
5. Periodically check and ensure that the guard rails and ladder are in their proper position, free from damage and that connectors are tight.
6. Do not allow horseplay on or under the bed and prohibit jumping on the bed.
7. Always use the ladder for entering and leaving the upper bunk

8. Do not use substitute parts. Contact Room and Board for replacement parts.
9. Use of a night-light may provide added safety precaution for a child using the upper bunk.
10. Always use guard rails on both long sides of the upper bunk. If the bunk bed will be placed next to the wall, the guardrail that runs the full length of the bed should be placed against the wall to prevent entrapment between the bed and wall.
11. The use of water or sleep floatation mattresses is prohibited.
12. **STRANGULATION HAZARD** – Never attach or hang items to any part of the bunk bed that are not designed for use with the bed; for example but not limited to hooks, belts, and jump ropes.
13. Keep these instructions for future reference.