

COMPASS WALL HOOK

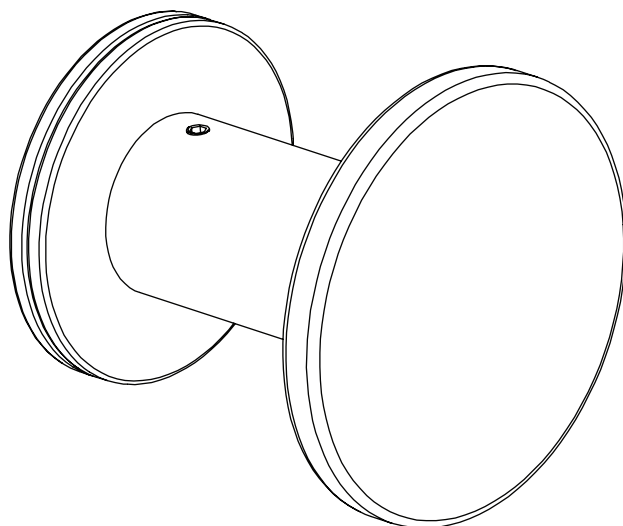

RECOMMENDED TOOLS AND MATERIALS:

Allen wrench (included)
1/16" Drill bit

#2 Phillips screwdriver
Power drill

Pencil

THIS PRODUCT INCLUDES:

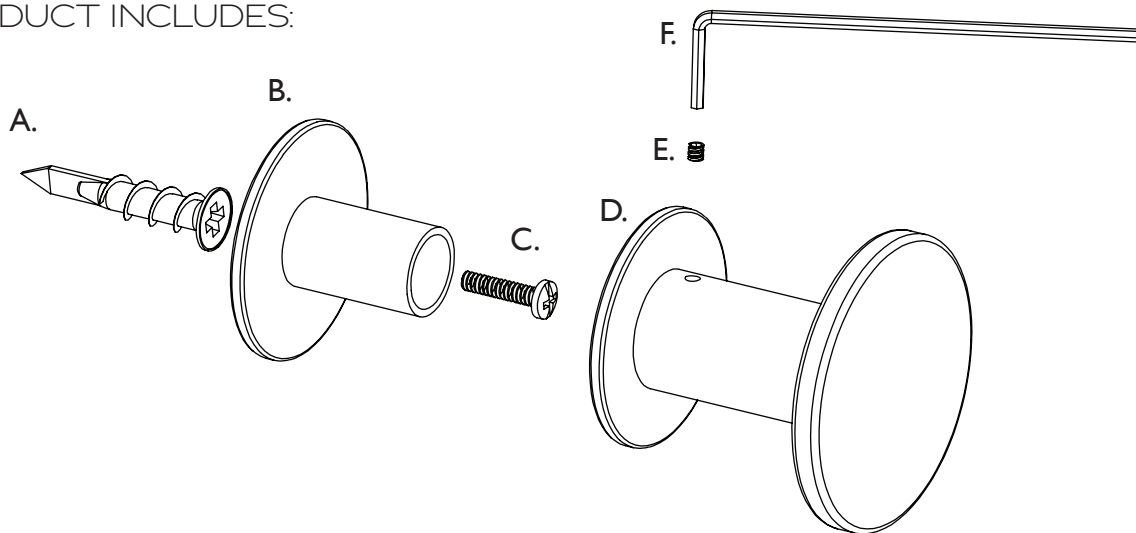

A. - Wall anchor
B. - Mounting plate
C. - Machine screw
D. - Compass hook

E. - Set screw
F. - Allen wrench

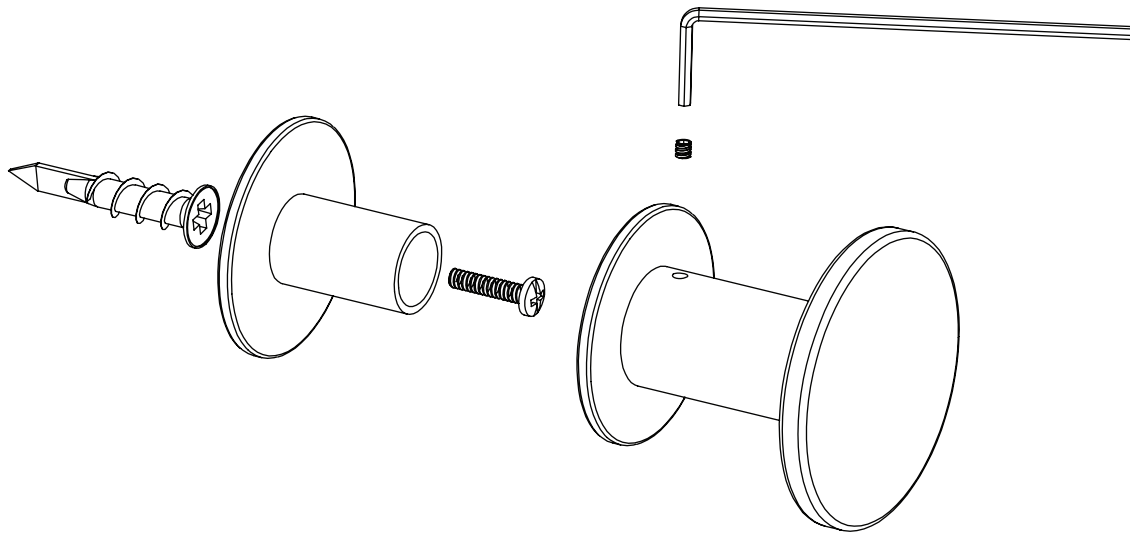

1

Hold the mounting plate to your wall in the desired location. Use a pencil to mark your wall through the center hole inside the mounting plate tube.

2

With a power drill, use a 1/16" drill bit to drill a pilot hole at your mark. Then use a screwdriver or drill to drill the wall anchor in fully. Be sure to drill the anchors in fully so they are flush with the wall before continuing to the next step.

3

Place and hold the mounting plate over the wall anchor so the center hole aligns with the wall anchor. Using a #2 Phillips screwdriver, insert the machine screw through the mounting plate and into the wall anchor. Tighten the screw fully until the mounting plate is flush and firmly mounted to the wall.

4

Slide the Compass hook over the mounting plate tube. Tighten the set screw through the small hole in the Compass hook with the provided Allen wrench.

SPECIAL CONSIDERATIONS:

The maximum recommended load for this product is 30 pounds. If you are mounting this wall hook to a surface other than drywall, or if you are uncertain about assembly, please contact a professional for help with installation.