

Gallery Shelf Assembly Instructions

List of parts:

- 2 side frames
- 5 shelves
- 1 3/4" x 3/4" x 1/2" L-bracket
- 1 drywall anchor
- 1 #8 x 5/8" brass screw
- 1 #6 x 2" drywall screw
- 21 #7 x 7/8" flat-head screws
- 14 clear plastic bumpers
- 20 #7 x 7/8" flat-head screws

Tools needed:

- Phillips screwdriver

Directions:

1. Lay out the two side rails on a soft, flat surface. Note which side rail is right and which is left. The attached steel shelf-mounting brackets should all face inward on both rails.
2. Start with the right side rail and attach the largest shelf to the first steel bracket mounted just above the leg. Insert screws into underside of shelf bracket and then up into the pre-drilled holes on the right side of the shelf. Tighten using a Phillips screwdriver (Figure 1).
3. Continue adding progressively smaller shelves to the right side until all five are attached with the smallest shelf on top (Figure 2).
4. Repeat steps 2 and 3 with the left side rail (Figure 3).
5. Place a plastic bumper in each corner on the back of every shelf. In addition, place two bumpers on the top back of each side rail pole for extra wall protection.
6. Tip unit upright next to the wall, moving the unit slightly so the top of frame, or top shelf, touches the wall first (Figure 4).
7. For safety, secure the desk to the wall with the drywall bracket (Figure 5). Find an appropriate location along a back edge of one of the top shelves; it does not need to be centered. Anchoring to a wall stud is best, but if you cannot find a stud, a drywall anchor will work as well.



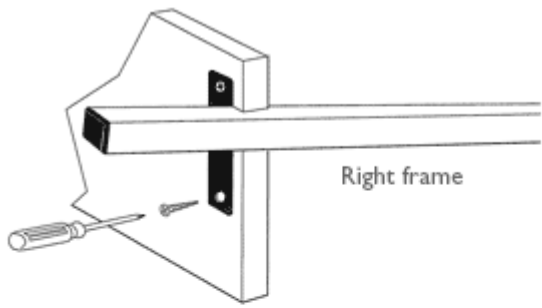

Figure 1

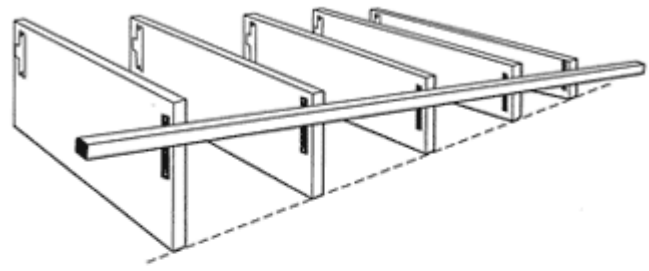

Figure 2

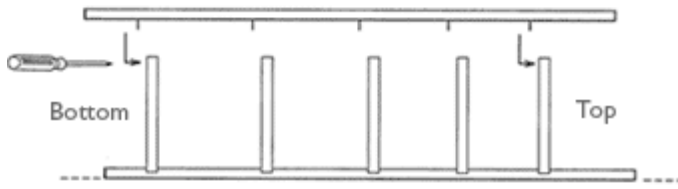

Figure 3

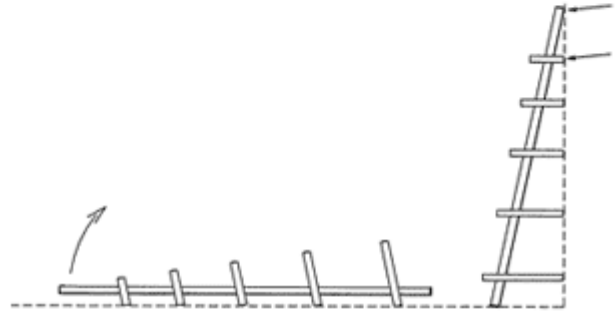

Figure 4

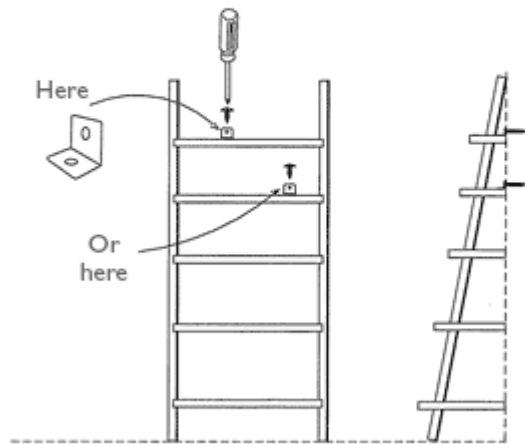

Figure 5