

### PIER WALL HOOK

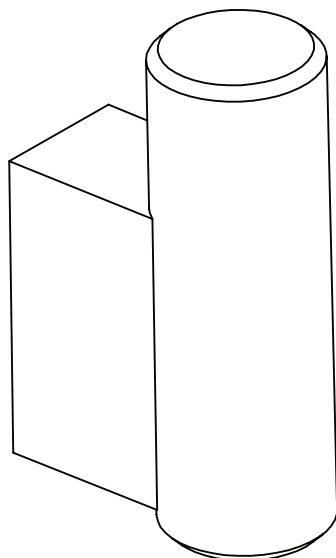

#### RECOMMENDED TOOLS AND MATERIALS:

Allen wrench (included)  
1/16" drill bit

#2 Phillips screwdriver  
Power drill

Pencil  
Level

#### THIS PRODUCT INCLUDES:

- A. Wall anchors (2)
- B. Drywall screws (2)
- C. Mounting block
- D. Pier wall hook
- E. Set screw
- F. Allen wrench

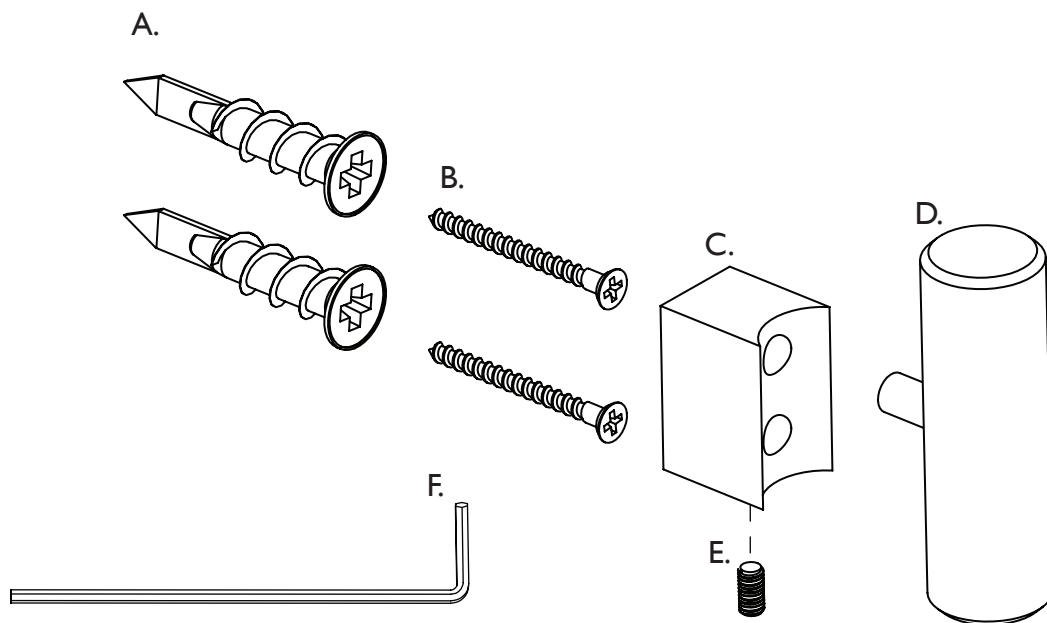

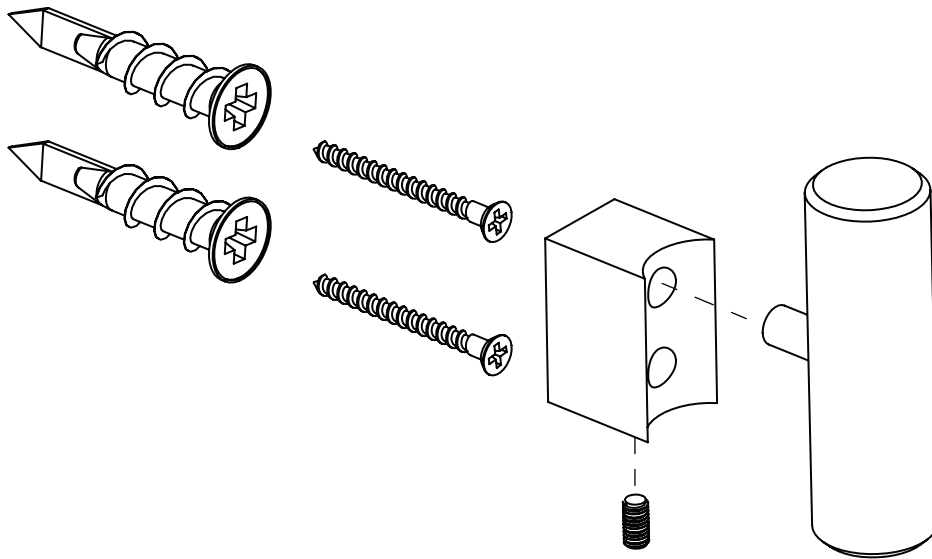

1

Use a level and a pencil to mark the placement of your hook. With a power drill, use a 1/16" drill bit to drill pilot holes where you want your hook. Using a #2 Phillips screwdriver, screw in the wall anchor so it is flush with your wall. Use care not to drive the anchors in past the surface of the drywall.

2

Hold the mounting block over the wall anchor so the mounting block's holes align with the wall anchor and the set screw hole faces down. Using a #2 Phillips screwdriver, insert the drywall screw through the mounting block and into the wall anchor. While ensuring the mounting block is level, tighten the drywall screws until the mounting plate is flush with your wall.

3

Insert the Pier wall hook into the mounting block with the longer end on the bottom. Press the Pier wall hook firmly into the mounting block, then tighten the set screw in the bottom of the mounting block using the provided Allen wrench.

### SPECIAL CONSIDERATIONS:

The maximum recommended load for this product is 30 pounds. If you are mounting this wall hook to a surface other than drywall, or if you are uncertain about assembly, please contact a professional for help with installation.